

**INTERCEPTOR**  
**MODEL 200**



**OWNER'S MANUAL**

**INTERCEPTOR CORP.**

**1700 Lexington Street  
Norman, Oklahoma**

# TABLE OF CONTENTS

<b>PART</b>	<b>PAGE</b>
DESCRIPTIVE DATA .....	i
STANDARD EQUIPMENT LIST .....	ii
3 VIEW .....	iii
I DESCRIPTION AND OPERATION OF SYSTEMS .....	1-1
II OPERATING CHECK LIST .....	2-1
III NORMAL PROCEDURES .....	3-1
IV EMERGENCY PROCEDURES .....	4-1
V PERFORMANCE .....	5-1
VI GENERAL CARE, SERVICING AND MAINTENANCE .....	6-1

## STANDARD EQUIPMENT

### ENGINE INSTRUMENTS

Recording tachometer  
Fuel pressure warning light  
Manifold pressure gauge  
Hydraulic pressure gauge  
Hydraulic pressure "OFF" control  
Cylinder head temperature gauge  
Fuel quantity gauge  
Oil pressure gauge-oil temp. gauge  
Ammeter  
Vacuum gauge  
ALL VERNIER engine controls

Steerable nose wheel  
Flap position indicator, instrument panel mounted  
Flap position handle, automatic flap follow-up system  
Parking brake  
Cowl flaps  
Stainless rubber cables  
Front wheel mud scraper  
Center-mounted radio panel

### ENGINE ACCESSORIES

Vacuum pump  
Hydraulic pump (engine driven)  
Fuel flow gauge (injection)  
Alternate air intake  
Stainless steel exhaust system  
Steel plumbing fittings  
(fwd. firewall)  
ABROQUTP fuel lines (armored)  
Stainless steel firewall  
Fuel pressure "warning" light  
Three piece engine cowling  
Propeller governor (Woodward)  
50 ampere generator  
Intake air filter  
Bed type engine mount  
Stainless hydraulic lines  
Electric auxiliary fuel pump,  
2 speed  
Vacuum regulator  
Outside service plug (starting)  
Oil access doors in cowling

### CABIN FURNISHINGS

Super soundproofing  
Sun visor  
Electric switch console  
Circuit breaker system  
Bad weather window  
Map light, variable red or white  
Post instrument lighting, red  
Instrument flood lighting, white  
Four-way fuel selector valve  
Choice of five interior colors  
Glove soft vinyl or cloth seat upholstery  
Map case  
Windshield defrosters (two)  
Heating and ventilating system,  
9 vent ports  
Cigarette lighter  
Ash trays (front and rear)  
Adjustable front seats  
Two rear seats; removable  
for cargo  
Rich super-thick floor carpeting  
Baggage compartment the down  
rings

### FLIGHT EQUIPMENT

Two landing lights (in nose cowl)  
Heated pitot tube  
Sensitive altimeter  
Airspeed indicator  
Magnetic compass  
Two flashing beacons  
Rate of climb  
Turn and bank indicator  
(vacuum driven)  
Toe brakes  
Outside air temperature gauge,  
remote instrument panel  
mounted  
8-day clock  
Dual controls

Shoulder harness (front and rear)  
Arm rests (front and rear)  
Spacious hat shelf, aft of rear seat  
Retracting step (right side)  
Non-skid wingwalk  
Outside baggage door  
Quickly removable main door

## DESCRIPTIVE DATA

### TYPE

—Four place, all-metal, low wing, retractable, tricycle geared monoplane.

### ENGINE

—Continental IO-520-A, six cylinder opposed, 285 HP engine.

### PROPELLER

—McCaughey D2A34C58/30AT-8 Constant-speed all metal propeller.

SPAN..... 30 ft. 6 in.  
LENGTH..... 24 ft. 4 in.  
HEIGHT..... 7 ft. 4 in.  
GROSS WEIGHT..... 3000 lbs.  
EMPTY WEIGHT..... 1985 lbs.  
USEFUL LOAD..... 1015 lbs.  
WING AREA..... 161.5 sq. ft.  
WING LOADING..... 18.6 lbs/sq. ft.  
POWER LOADING..... 10.5 lbs/H.P.  
BAGGAGE CAPACITY..... 200 lbs.  
STALL SPEED, LANDING CONFIGURATION..... 62 MPH CAS  
STALL SPEED, CLEAN CONFIGURATION..... 77 MPH CAS  
TOTAL FUEL CAPACITY..... 80 Gal.

# COMMANDER 200

## Part I

### DESCRIPTION AND OPERATION OF SYSTEMS

The AERO COMMANDER 200 is a low-wing, retractable tricycle gear airplane powered by a Continental IO-520A, 285 HP engine. It won the world speed record for single engine aircraft of Class C-1 in 1965. The airplane features a spacious, four-place cabin with luxurious upholstery and super soundproofing. This adds to the comfort of the crew and passengers and is a feature usually found only in larger passenger aircraft.

#### FLIGHT CONTROLS

Control surfaces are operated through push-pull rods and conventional closed-circuit cable systems terminating in bell cranks. The preformed steel cables run over phenolic pulleys. The elevator and aileron surfaces are operated by conventional movement of dual control wheels. One control wheel is located directly in front of each front seat and operates through the primary instrument panels. Dual rudder pedals are provided and incorporate hydraulic toe-brakes on the left side.

#### TRIM CONTROLS

Elevator trim is controlled by a vernier control knob located on the instrument panel to the right of the prop control. Turning the knob clockwise trims the airplane nose down. An elevator tab indicator is located below the elevator trim control.

Aileron trim is controlled by a knob located on the instrument panel to the left of the gear handle. Turning the knob clockwise corrects for left wing heaviness.

#### Wing Flaps

The hydraulically operated wing flaps are controlled by a variable position flap lever located on the instrument panel below and to the right of the elevator trim control. A flap indicator with a range of 0° to 40° is located on the right side of the instrument panel.

#### POWER PLANT CONTROLS

##### Throttle, Propeller, and Mixture

The vernier push-pull throttle, propeller, and mixture controls are conventionally located in the center of the instrument panel. Each control is released for repositioning by pushing a button on the knob. With the control secured, fine adjustments can be accomplished by rotating the knob.

If oil pressure is lost, the propeller will go into full low pitch (high rpm) position. This occurs because propeller high pitch (low rpm) is obtained by governor boosted engine oil pressure working against the centrifugal twisting moment of the blades.

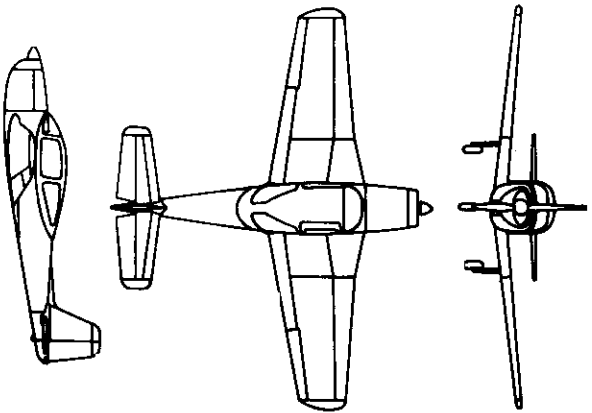

DIMENSIONS	
Span	30'8"
Length	24'4"
Height	7'4"
WEIGHTS	
Empty, lb.	1,985
Gross, lbs.	3,000
Useful, lbs.	1,015
LOADINGS	
Wing, lbs. per sq. ft.	18.6
Power, lbs. per hp	10.5

### Alternate Air

If the air intake becomes clogged with dirt, ice, etc., a spring loaded door in the air intake duct will open automatically and the induction system will operate on alternate air. (See Induction System Icing, Part III).

### Cowl Flap

The T-handle push-pull cowl flap control is located on the left side of the instrument panel. The cowl flaps should be open during ground operation, take-off and climb. Intermediate cowl positions may be selected. Rotating the T-handle clockwise will lock the control.

## LANDING GEAR SYSTEM

### Gear Selector

The landing gear is controlled by a three-position gear selector handle located on the instrument panel to the left of the mixture control. When gear and flaps are retracted, the gear selector should be placed in the CENTER position, this reduces hydraulic pressure in the system. The landing gear selector must be in the DOWN position to start the engine.

### Position Light (press to test) Indicators

Landing gear position lights are located in the forward portion of the electrical switch panel. The lights, red for gear UP and green for gear DOWN, come on only when the gear is placed in the fully retracted or extended position. A light control rheostat is located on the forward side of the electrical switch panel to control the intensity of these lights.

### Safety Switch

To prevent inadvertent retraction of the landing gear, the gear selector must be in the DOWN position before the starter will engage.

### Warning Horn

In flight with the landing gear retracted, if the throttle is retarded below a power setting sufficient to sustain level flight, a warning horn on the cabin forward bulkhead will sound.

### Manual Extension

In the event of a hydraulic failure, landing gear extension can be accomplished by following this procedure.

Slow airplane to below 100 mph, place gear selector handle in "DOWN" position, and operate hand pump located on left side of pilot's legs. After operation of hand pump, if gear does not lock, yaw airplane left and right until green lights indicate that gear is locked. Retard throttle to idle to recheck with gear warning horn.

With only an engine driven hydraulic pump failure, the hand pump will force the gear into the locked position. However, with a complete hydraulic failure, the gear may have to be locked by yawing the airplane if the gear does not lock of its own weight.

### Brakes

The brakes on the main landing gear wheels are operated by applying toe pressure to the rudder pedals. The parking brake push-pull control is located to the left of the aileron trim knob located on the instrument panel. To set the parking brake, press each toe pedal until solid resistance is felt and pull the parking brake control out. To release the brakes, push the control in.

#### NOTE

The parking brake should be left off and wheel chocks installed if the airplane is to be left unattended. Changes in temperature can cause the brakes to release or to exert excessive pressures.

## INSTRUMENTS

### Engine Instruments

Oil temperature, oil pressure, and cylinder head temperature gauges are located in the right primary instrument panel together with the tachometer, manifold pressure gauge and fuel flow indicator.

## FUEL SYSTEM

### Fuel Tanks

An 80-gallon fuel capacity is provided by four fuel tanks in the wings. The filler neck for each tank is accessible through an access door in the top of the wing. The engine-driven fuel injector pump returns approximately 10 gallons of excess fuel per hour to the tank from which fuel is being drawn. The fuel system contains five drains; the individual fuel tank sumps and gascolator, located on the underside of the wing.

### Fuel Quantity Gages

Fuel quantity is measured by float type transmitter units which convey signals to one gage, located on the electrical switch panel. This fuel gage indicates quantity of fuel for fuel tank selected.

### Fuel Flow Indicator

The fuel flow indicator is a metered fuel pressure gage calibrated in gallons per hour. A red radial mark is placed at the maximum allowable fuel pressures, as indicated at the fuel injection manifold valve. When the unmeasured fuel pressure drops below 5 psi, a red warning light located on the left primary instrument panel illuminates.

### Auxiliary Fuel Pump

The electric auxiliary fuel pump is controlled by a three position ON-OFF-START toggle switch located to the right of the magneto switch on the stationary panel. A check valve permits boost pressure from the auxiliary pump to bypass the engine-driven pump for engine starting. Immediately after starting the auxiliary fuel pump can be used to purge the system of vapor caused by an extremely high temperature or a start with the engine hot. The auxiliary fuel pump

Provides sufficient fuel pressure for maximum engine performance should the engine-driven pump fail.

### Fuel Management

The fuel selector valve handle is located forward and to the left of the left front seat. Ordinarily, take-offs and landings should be made using the best main fuel tank. The auxiliary fuel tanks are to be used in level flight only.

If desired, fuel can be drawn from any tank until engine operation indicates that the tank is empty. The best time to switch tanks is immediately after noting a fluctuation in fuel flow. However, if the engine is allowed to stop from fuel starvation, it is important that the following procedures be observed.

1. Retard the throttle to prevent an engine over-speed condition.
2. Switch to the other tank, visually checking the fuel selector valve and fuel quantity gage.
3. Turn the auxiliary fuel pump on **MOMENTARILY** until power is regained.
4. Advance the throttle to the desired position.

### OIL SYSTEM

The engine oil system is the full-pressure, wet sump type and has a 12--quart capacity. Oil operating temperatures are controlled by an automatic thermostat bypass control. The bypass control will limit oil flow through the oil cooler when operating temperatures are below normal and will permit the oil to bypass the cooler if it should become blocked.

### ELECTRICAL SYSTEM

In general, electrical wiring is the single-wire type, with the aircraft structure used as the ground return. The electrical switch panel contains the battery, generator and all other system switches and circuit breakers.

### Battery

A 35-ampere-hour, 12-volt battery is located on the right hand forward side of the firewall. Battery servicing procedures are described in Part VI.

### Generator

A 50-ampere, 12-volt, belt-driven generator is standard equipment. The generator is designed to maintain the full 50-ampere output at 1700 rpm.

A voltage regulator automatically adjusts generator output to the required electrical load, including battery recharging. Charge or discharge of the battery is indicated by the ammeter located in the right hand primary panel.

The generator circuit breaker is located on the forward side of the electrical switch panel.

1. Reset the generator circuit breaker by pressing in.
2. If the overvoltage condition does not recur, continue to use the generator.
3. Should the overvoltage condition persist, turn the generator **OFF**, and minimize electrical current consumption, since only

battery power will now be available. Have the malfunction corrected before the next flight.

Refer to Part VI for minor maintenance of the generator.

### Starter

The starter is relay-controlled to minimize the length of heavy cable required to carry the high amperage of the starter circuit. The starter is actuated by a push-button switch.

### Interior Lighting

The intensity of the instrument and flood lights are adjusted by a two position dual rheostat located to the lower right on the instrument panel. The instrument **post** lighting is controlled when the rheostat control knob is pushed in and pulling the rheostat control knob out allows for adjustments of **flood** lighting. The navigation light toggle switch located on the electrical switch panel must be in the ON position to operate the instrument light rheostat.

### Exterior Lighting

Switches for all exterior lights, including the rotating beacons, are located on the electrical switch panel. In addition to the navigation lights on the wing tips and tail cone, landing lights in the nose section are standard equipment. Each landing light is operated by a separate switch, and can be used for both approach and taxiing. For longer battery and lamp service life, use the landing lights sparingly. Avoid prolonged operation during ground maneuvering, which could cause overheating.

### HEATING AND VENTILATING SYSTEM

#### Cabin Heating

A heater muffler on the right and left engine exhaust stock provides for heated air to seven outlets in forward and aft areas of the cabin. One forward outlet is located to the side of each pair of rudder pedals; aft outlets are installed behind the front seats. Two outlets provide heated air for windshield defrosting. A seventh outlet is located below and forward of the right front seat on the side panel.

In flight, ram air enters intakes at the rear engine baffle, passes through the heater mufflers and the heater valve assemblies which are located in the right and left side of the forward firewall.

#### Heater Operation

1. Pull out the HOT AIR controls. One control is located beside the electric fuel pump toggle switch on the left side of the instrument panel. The other control is located on the lower right side of the instrument panel.
2. The HOT AIR controls vary the amount of heated air. The amount of heated air is increased as the control is pulled out. The control on the right side of the instrument panel controls HOT AIR to the right side of the aircraft and the control on the left controls the left side.
3. Heated air from the two aft outlets, can be regulated by rotating the gate valves to select desired outlet quantity.
4. Windshield defrosting is controlled by the HOT AIR controls.
5. To render the heating system inoperative, push the HOT AIR controls in all the way.

# AERO COMMANDER 200

## Part II

### OPERATING CHECK LIST

Part II lists the steps necessary to operate your Aero Commander 200 efficiently and safely. It is not a check list in its true form as it is considerably longer, but it does cover briefly all of the points that you should know concerning the operation of your Aero Commander 200.

#### Individual Fresh Air Outlets

Fresh air from a scoop on top and forward of the windshield is ducted to individual outlets located to the side of each seat. Each outlet can be positioned to direct the flow of air as desired. The volume of incoming air can be regulated by rotating the outlet. A shut-off COLD AIR valve is operated by a push-pull control located on the instrument panel between the left HOT AIR and PARK BRAKE control.

#### Exhaust Vents

A cabin air exhaust vent is located on the bottom center of the fuselage.

#### STALL WARNING HORN

A stall warning horn on the forward side of the instrument panel sounds a warning signal while there is ample time for the pilot to correct his attitude. The horn is triggered by a sensing vane on the leading edge of the left wing and is equally effective at all flight attitudes, weights, and airspeeds. The signal is irregular and intermittent at first, but will become steady as the airplane approaches a complete stall.

#### SEATING

To adjust front seats, pull up on the release bar below the center of the seat and slide the seat forward or aft, as desired.

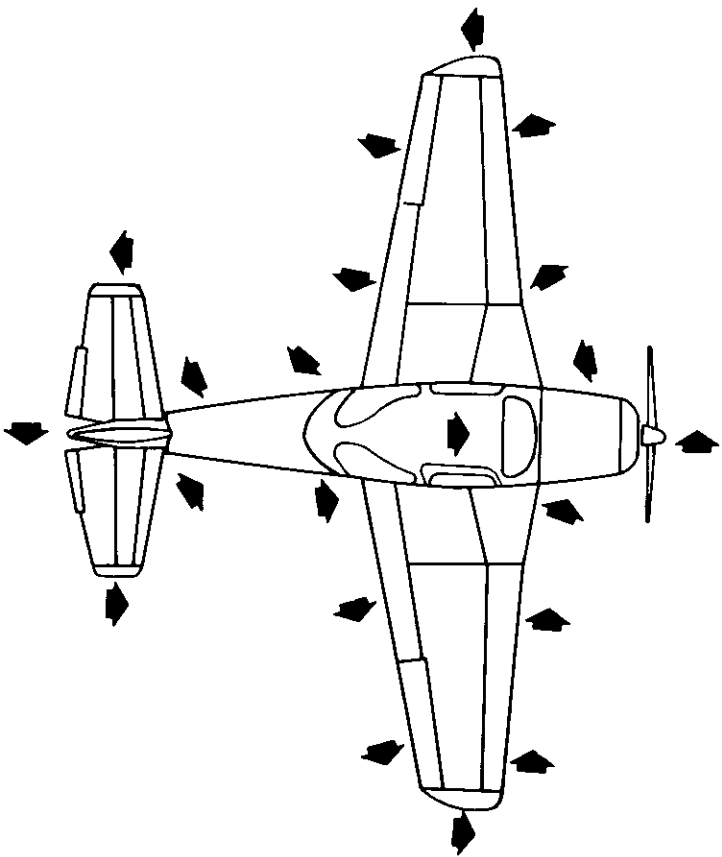

## PROCEDURES AND MANEUVERS FOR AERO COMMANDER MODEL 200 CHECKOUT

### A. Preflight

1. Cockpit—Check forms, trim neutral, turn battery switch on and check the fuel quantity in each tank. Turn battery switch off.
2. Baggage Compartment—Open compartment door and obtain sump checking tool.
3. Right Wing Flap—Check condition and security.
4. Right Aileron—Check travel and security.
5. Right Wing Tip—Check condition.
6. Right Wing Tie-Down—Removed.
7. Right Wing Leading Edge—Check condition, stall strip secure.
8. Right Auxiliary Fuel Tanks—Visually check fuel level and secure.
9. Right Main Fuel Tank—Visually check fuel level and secure.
10. Right Auxiliary Fuel Tank Drain—Check for contaminated fuel.
11. Right Main Gear—Check tire condition, brake, hydraulic lines and gear uplock cables, shock strut extension (3/8 inches), wheel well doors, chocks removed.
12. Right Main Fuel Tank Drain—Check for contaminated fuel.
13. Nose Gear—Tire condition, wheel well doors, uplock and cable, shock strut extension (1 3/4 inches), chocks removed.
14. Propeller—Check condition.
15. Oil Filter Cap—Secure.
16. Oil Quantity—10-12 Quarts.
17. Engine—General condition.
18. Cowl Flap—Check condition and security.
19. Exhaust Stacks—Check condition and security.
20. Fuel System Drain—Check for contaminated fuel.
21. Left Main Fuel Tank Drain—Check for contaminated fuel.
22. Left Main Landing Gear—Check tire condition, brake, hydraulic lines and gear uplock cables, shock strut extension (3/8 inches), wheel well doors, chocks removed.
23. Left Auxiliary Fuel Tank Drain—Check for fuel contamination.
24. Left Main Tank—Visually check fuel quantity and secure filter.
25. Left Auxiliary Tank—Visually check fuel quantity and secure cap.
26. Left Wing Leading Edge—Check condition, stall strip secure, stall warning indicator condition.
27. Left Wing Tie-Down—Removed.
28. Left Wing Tip—Check condition.
29. Left Aileron—Check travel and security.
30. Pitot Tube—Check cover removed and condition.
31. Left Wing Flap—Check security.
32. Elevator Trim Tabs—Check security and zero position alignment.
33. Elevator—Check security, travel, and bungee condition.
34. Rudder—Check security and travel.
35. Radio Antenna—Check condition.
36. Slow sump checking tool and secure baggage compartment.

### Before Starting

1. Brakes—SET
2. Fuel selector valve—Select Main Tank more nearly full
3. Landing gear selector—DOWN
4. All avionic equipment—OFF
5. Generator—OFF

### CAUTION

Always leave the Generator switch OFF for starting (both with and without external power) and when using external power for electrical equipment checkout. This protects the voltage regulator and electrical equipment.

6. Battery switch—ON
7. All circuit breakers, switches, and controls—CHECKED.
8. Cowl flaps—OPEN

### Starting

1. Mixture—FULL. RICH at elevations below 5000 feet; above 5000 feet pull control out 1/4 to 1/2 of its travel.
2. Propeller—HIGH RPM (full forward)
3. Auxiliary Fuel Pump:
  - a. Normal start—Auxiliary fuel pump switch in the ON position until fuel flow peaks, then OFF
  - b. Hot Start—Auxiliary fuel pump switch in START position until fuel flow stabilizes, indicating system is purged of fuel vapor, then OFF
  4. Throttle—Set for 1000 to 1200 rpm
  5. Magneto switch—BOTH depress starter switch and release when engine fires.
6. In event of Overprime Condition:
  - a. Mixture—IDLE CUT-OFF
  - b. Throttle—OPEN
  - c. Depress starter switch
  - d. As engine starts, reduce throttle to IDLE RPM and place mixture control in FULL RICH position
7. Auxiliary fuel pump—START position after starting, if necessary, to purge system of any remaining vapor, then OFF.

### Before Takeoff (After obtaining 75° oil temperature)

1. Anti-collision Light—ON
2. Cowl flaps—OPEN
3. Engine Run-up—CHECK MAGS AND EXERCISE PROP AT 1700 RPM (An unequal RPM drop between mags exceeding 50 RPM is excessive)
4. Flaps—Checked and set for takeoff.
5. Controls—FREE AND FULL TRAVEL
6. Instruments—Check engine and flight instruments.
7. Gas—BEST MAIN TANK—MIXTURE RICH
8. Altimeter—SET to field elevation.
9. Radio—TAKEOFF CLEARANCE
10. Trim—SET FOR TAKEOFF (Turn knob to full nose down and turn nose up four half-turns)
11. Interior—Door, windows and seat belts.
12. Propeller—HIGH RPM



**NORMAL PROCEDURES****Before Landing**

1. Gas—BEST MAIN TANK—MIXTURE RICH
2. Altimeter—SET
3. Gear—DOWN AND LOCKED (3 Green Lights—Hydraulic Pressure up)
4. Brakes—CHECKED for normal pedal resistance
5. Propeller—HIGH RPM
6. Flaps—AS DESIRED

**Shutdown**

1. Electrical and radio equipment—OFF
2. Flaps—UP
3. Cowl flaps—OPEN
4. Propeller—HIGH RPM
5. Throttle—1000 RPM
6. Mixture—IDLE CUT-OFF
7. Magneto switch—OFF after engine stops
8. Battery and Generator switches—OFF
9. All switches—OFF
10. Secure Controls
11. Install wheel chocks

**Starting**

Refer to the starting Check List in Part II. Make sure that the area around the propeller is clear and free from loose objects. Avoid operating the engine on loose gravel or sand if possible.

Each cranking period should be limited to 30 seconds. Allow the starter to cool for five minutes between cranking periods to prolong starter brush life.

After the engine is started, check for oil pressure indication. If no pressure in 30 seconds (60 seconds in cold weather), stop the engine and investigate.

In high air temperatures and during hot engine starts, if there is evidence of vapor in the fuel system (fluctuating fuel flow), operate the auxiliary fuel pump until the fuel flow is stable and the engine operates smoothly.

**Taxiing**

**NEVER TAXI WITH A FLAT SHOCK STRUT;** damage to the airplane can occur during both ground operation and landing gear retraction.

To taxi, release the parking brake control and allow the airplane to roll forward. Check the brakes by applying them several times lightly. Govern your taxi speed with throttle coordination and avoid use of brakes. Most turns can be made with the steerable nose wheel and no brakes. Sharp turns can be accomplished by applying some brake on the inside wheel. When taxiing over rough surfaces, use minimum power and light braking pressure, and hold the control column full back.

**Before Take-Off**

Consult the Before Take-Off Check List in Part II. To avoid propeller damage, do not perform engine run-up on loose gravel.

If there is a difference of more than 50 rpm between the right and left magnetos or the rpm drop is excessive for either magneto, continue to warm up the engine a minute or two longer, then recheck magnetos.

**Take-Off**

Full throttle operation is recommended during take-off to minimize take-off roll. For take-off from fields at higher altitudes, the mixture should be adjusted for field elevation to insure maximum engine power.

**Climb**

For cruise climb, establish a power configuration of 2500 rpm and 25 inches Hg with an airspeed of approximately 140 mph (121 knots) IAS.

## Cruise

There is no "best cruise power setting for all flights." Your choice of power settings will depend upon load, desired range, altitude, temperature, and perhaps most important, the purpose of your flight.

Normal cruise control (65% to 75% power) should be used for all flying when weather and distance are well within the normal operating limitations of the airplane and its pilot. For maximum range, level flight cruise operations should be at the lowest power that will satisfy the speed requirements.

## Stalls

The stall warning indicator gives aural indication of an impending stall at approximately 5 mph to 10 mph above the stall.

## Obstacle Landing

A slow power approach with full flaps is desired. A general procedure would be:

1. Plan a longer than normal final.
2. Lower flaps to the FULL position on base leg.
3. Set up the appropriate airspeed for power approach trim.
4. Use power to control the rate of sink.
5. Cut power on touchdown.
6. Lower the nose wheel and retract flaps immediately.
7. Apply brakes as required. Remember that excessive braking on unimproved surfaces may place major stress on the nose gear.

## COLD WEATHER OPERATION

### Pre-Flight Inspection

In addition to the normal pre-flight exterior inspection, remove ice, snow, and frost from the wings, tail, control surfaces and hinges, propeller, windshield, pilot, fuel vents, and engine breather line. (If you have no way of removing these formations, do not fly the airplane.) Complete your normal pre-flight procedures, including a check of the flight controls for complete freedom of movement.

Close attention to draining the tank and engine sumps should be of particular importance during cold weather.

### Starting

Use engine oil in accordance with Engine Manufacturers Specifications.

Under very cold conditions, it may be necessary to pre-heat the engine prior to a start. Always pull the propeller through by hand several times to clear the engine and "limber up" the cold, heavy oil before using the starter.

If the airplane is equipped with the optional external power receptacle, it is advisable to use external power.

Normal engine starting procedures will ordinarily be used, except it may be necessary to leave the auxiliary fuel pump ON until the engine starts.

## Engine Warm-Up

If there is no oil pressure within the first 60 seconds of running, or if oil pressure drops after a few minutes of ground operation, shut down and check for broken oil lines, oil cooler leaks or the possibility of congealed oil.

During warm-up, watch the engine temperature closely, since it is quite possible to exceed the cylinder head temperature limit in trying to bring up the oil temperature. Exercise the propeller several times to remove cold oil from the pitch change cylinder.

## Taxing

Avoid taxiing through water, slush or muddy surfaces if possible. Water, slush or mud, when splashed on the wings and tail surfaces may freeze, increasing weight and drag and perhaps limiting control surface movement. Use the brakes sparingly. Taxi slowly for best control and to protect the airplane from flying water, slush, or ice.

## Before Take-Off

In addition to the usual before take-off checks:

1. Turn pitot heat ON, (if necessary).
2. Pull out the CABIN HEAT controls. Adjust AFT CABIN HEAT GATE VALVES to divert a larger volume of air to the defroster outlets and rotate windshield defroster valves to the OPEN position.
3. Cycle the propeller several times to flush cold oil from the pitch change cylinder.

## Take-Off

Should the landing gear become wet from running through water or ice, delay retraction until the gear has had time to dry. If retracted when wet, it is possible for the gear doors to freeze in the UP position.

## Propeller

In flight, after power settings have been established and the airplane trimmed, the movements of the pitch change mechanism are very small. The propeller should be exercised occasionally to flush cold oil from the pitch change cylinder.

Ice on the propeller blades can cause an out-of-balance condition resulting in rough engine operation. Rapid cycling of the propeller is often effective in removing propeller ice.

## Induction System Icing

The possibility of induction system icing is reduced by the non-icing characteristics of the fuel injection engine and the automatic alternate air source. The only possible ice accumulation is impact ice at the air intake and filter. If the air intake or filter becomes clogged with ice, a spring-loaded door in the air intake duct will open automatically and the induction system will operate on alternate air. Due to the loss of ram effect, a slight drop in manifold pressure will be noted.

## Descent

Throughout the descent, monitor cylinder head temperature and manifold pressure. In event of overcooling, decrease the rate of descent, lower the gear, and add power.

# COMMANDER 200

## Part IV

### EMERGENCY PROCEDURES

Emergency procedures are too often missed, skipped, or not studied properly. When an emergency occurs, the pilot who has studied the emergency procedures will perform calmly and efficiently. Panic itself is an emergency and can only be overcome by knowledge and proper training.

The following sections are provided to familiarize you with emergency procedures. Emergencies requiring set procedures are written step by step, in order that the procedures section may be used as a reference. It is recommended that you keep this manual easily accessible during flight.

#### OPEN CABIN DOOR

The Aero Commander 200 cabin door has more safety features designed into the latching mechanism than any other light aircraft, and should never open during flight if properly secured prior to take-off. However, if the safety latch mechanism was not engaged prior to flight and the door comes open during take-off or climb-out, it is recommended that you land and secure the door. If immediate landing is impossible an attempt for in-flight closing may be successful by employing the following procedures:

1. Maintain approximately 90 MPH airspeed.
2. Open the pilot window.
3. Yaw to the right first to assist further opening the door, then to the left simultaneously slamming the door.
4. Engage safety latch.

#### ACCIDENTAL SPINS

Intentional spins are prohibited. If a spin is inadvertently entered, apply the following procedures for recovery:

1. Retard throttle to the idle position.
2. Apply full rudder opposite the direction of the spin rotation.
3. Neutralize ailerons.
4. Apply forward pressure on the control wheel.
5. After rotation stops, apply back-pressure gently but positively to prevent excessive airspeed until level flight is obtained.

#### LANDING GEAR EXTENSION

There are three methods of landing gear extension incorporated on the Model 200:

1. Engine driven hydraulic pump developing 1000 to 1300 PSI (indicator located on right primary instrument panel).
2. Hand operated hydraulic pump developing required pressure.
3. A landing gear free-fall system.

The engine driven hydraulic system is the normal operating system and procedures are described in the operations sections, and therefore, are not applicable as an emergency procedure.

### Use of Hand Operated Hydraulic Pump

For emergency extension with the use of the hand pump:

1. Place the landing gear selector in the DOWN position.
2. Operate the hand pump until gear is DOWN and locked as shown by gear position indicator lights and throttle warning horn.

#### NOTE

Slow to below 100 MPH for emergency gear extension operations.

### USE OF FREE FALL SYSTEM

In case of complete hydraulic failure (loss of hydraulic fluid), free fall gear by placing the gear handle in the down position and yawing the airplane to lock it down. If normal uplock system malfunctions, uplocks can be released manually with red T-handles located on the floor below the left front seat.

### GEAR-UP LANDING

Whenever possible, choose to land beside a runway on grass or firm sod. Follow normal procedures until just prior to flare-out. At this time exercise the following:

1. Unlatch door.
2. Close throttle.
3. Mixture—OFF
4. Ignition switch—OFF
5. Master switch and all electrical switches—OFF
6. Fuel selector in OFF position.
7. Make normal landing, keeping wings level.

#### NOTE

Be sure to check landing gear "Press-to-Test" Position light for possible lamp failure (burnt out bulb).

### ENGINE FIRE

In the event of engine fire, close the cabin heat shut-off valves. If the cabin begins to fill with smoke, open the pilot window and proceed as follows with shutdown and forced landing procedures.

1. Mixture—IDLE CUT-OFF
2. Fuel selector—OFF
3. All switches OFF (BATTERY, GENERATOR, IGNITION)
4. Throttle—CLOSED
5. Gear—DOWN (if desired)
6. Do not attempt to restart engine

### ENGINE FAILURE

Should engine failure occur, the first step in any procedure is to lower the nose, set up and maintain a safe flying speed, (see operations section). Some of the most probable causes of engine failure are: fuel starvation, ignition malfunction, loss of oil and engine seizure.

Some of the symptoms usually appear prior to complete engine

failure. If the engine shows a decrease in power, starts running rough, or completely loses power, perform the following check:

1. Check that fuel selector is on a usable tank.  
If necessary to switch tanks, retard the throttle, switch to desired tank.
2. Turn fuel boost pump "ON," advance throttle slowly until power is regained, and then turn OFF fuel boost pump.
3. Place mixture full rich and then lean to altitude if necessary.
4. Check ignition switch for "BOTH" position
5. Check all engine instruments.

If a forced landing is unavoidable, follow normal forced landing procedures, insuring that the aircraft is properly shut down.

# COMMANDER 200

## Part V

### AERO COMMANDER 200 PERFORMANCE

The following recommended airspeeds have been established by flight tests and are considered good operating technique. As flight tests were conducted with the airplane and engine in good condition, allowances for actual conditions must be made.

#### AIRSPEEDS

##### Take-off speeds (IAS)

	MPH	Knots
Normal Take-off	80	65
Take-off	100	87
Climb Out @ 50 Feet	100	87
Obstacle or Soft Field Take-off (20° Flaps)		
Take-off	75	61
Climb Out @ 50 Feet	85	70

##### Climb Speeds (IAS)

Cruising Climb (Clean)	140	122
Best Rate-of-Climb Speed, S.L.	115	100

##### Landing Speeds (IAS)

Normal Approach (20° Flaps)	90	78
Obstacle Approach (40° Flaps)	80	70

Maximum Speed (mph) (MAX continuous power)	216
Cruise Speed, 7,500 Ft. 75% Power (mph)	210
Max. Range, 10,000 Ft. 65% Power	1060
80 Gal. Total Fuel (st. mi.)	1450
Sea Level Rate of Climb (fpm)	18,500
Service Ceiling (Ft.)	1150
Take-off Dist. over 50 Ft. (Ft.)	1150
Landing Dist. over 50 Ft. (Ft.)	1150

##### Stall Speeds

Altitude loss (as measured from the time the airplane stalls until horizontal flight is regained) in power-off stalls may be as high as 275 feet. The addition of power after the stall reduces the altitude loss considerably.

**STALL SPEEDS (Calibrated Airspeed MPH) POWER OFF AT GROSS WEIGHT**

Angle of Bank	0°	20°	40°	60°
Flaps Up	77	79½	88	109
Flaps 20° (Take-Off)	66½	68½	76	94
Flaps 40° (Landing)	62	64	71	88

**PERFORMANCE FOR STANDARD AIRCRAFT AT GROSS WEIGHT ON A STANDARD DAY.**

### AIRSPED LIMITATIONS

Red Line (never exceed) 236 mph (205 k)  
 Yellow Arc  
 (Caution—smooth air only) 210 to 236 mph (182 k-205 k)  
 Green Arc  
 (Normal operating speed) 77 to 210 mph (67 k-102 k)  
 White Arc (Flaps extended) 62 to 125 mph (54 k-109 k)  
 Max. Structural Cruising 210 mph (182 k)  
 Maneuvering 132 mph (115 k)  
 Max. Gear Retraction Speed 125 mph (109 k)  
 Emergency Gear Extension Speed 210 mph (182 k)  
 Max Gear Extended Speed 210 mph (182 k)

### ENGINE LIMITATIONS

**ENGINE LIMITS:** For all operations 285 hp 2700 rpm 29.3 in. Hg.

**FUEL:** 100/130 Minimum Grade Aviation Gasoline

### ENGINE INSTRUMENT MARKINGS

**POWER PLANT INSTRUMENTS**

Red Line—Maximum-Minimum,

(Do not operate under or over)

Yellow ARC—Caution Range

Green ARC—Normal operating Range

**OIL PRESSURE:**

Red Lines—10 PSI Min: 100 PSI Max.

Green ARC—30 PSI to 60 PSI

**OIL TEMPERATURE:**

Red Line—240°F

Green ARC—75°F (Take-off) to 240°F

**FUEL PRESSURE:**

Red Line—18.0 psi

Green ARC—3.5 psi to 18.0 psi (Operating Range)

**TACHOMETER:**

Red Line—2700 rpm

Green ARC—600 rpm to 2700 rpm

**CYLINDER HEAD TEMPERATURE:**

Red Line—460°F, Bayonet Thermocouple

**HYDRAULIC PRESSURE:**

Red Line—1000 psi min., 1300 psi max.

Green ARC—1000 psi to 1300 psi

**MANIFOLD PRESSURE:**

Red Line—29.3 in. Hg.

Green ARC—10.0 in. Hg. to 29.3 in. Hg.

### MANEUVERS

No acrobatic maneuvers, including spins, approved. Maneuvers involving full application of elevator, rudder or aileron should be confined to speeds at or below the maneuvering speed.

### WEIGHT AND BALANCE

At the time of delivery of each airplane, Aero Commander Incorporated provides an Airplane Flight manual which includes all of the necessary data the owner or pilot may need in order to arrive at the necessary weight and balance computation to assure proper loading.

# COMMANDER 200

## Part VI

### GENERAL CARE, SERVICING AND MAINTENANCE

The purpose of this section is to acquaint you with the general and special servicing and maintenance features of the Model 200. Use it as a guide for proper care and preventative maintenance.

### CLEANING

#### CAUTION

Allow for a cure period of 90 days before applying wax or polish. Waxes and polishes seal the paint from the air and prevent curing.

The exterior of the aircraft has been painted with a high quality paint that will protect the metal skin and give years of lasting beauty, if properly cared for. Climatic and operating conditions will determine the extent and frequency of cleaning required. The aircraft should be washed more frequently when operating near salt water, as the salt-laden moisture of the air will cause corrosion to the metal surfaces. To wash the aircraft use a mild soap and water solution and rinse thoroughly with clear water. After the 90-day cure period keep your aircraft waxed.

Prior to cleaning, or washing the airplane: Attach the pitot cover and close all openings. Avoid harsh detergents which could cause corrosion or scratches, and use soft cleaning cloths or a chammois during all cleaning and polishing operations.

### WINDSHIELD AND WINDOWS

Exercise caution to prevent damage to plexiglass windshield and windows. Never wipe with dry material and never wipe or clean on a dry surface. Wash the surface with a clean, mild soap and water solution or use a plexiglass cleaner furnished by your Aero Commander dealer's Service Department.

### INTERIOR

Frequent cleaning of the interior is recommended. Use products recommended by your Service Department to insure maximum durability and beauty. These products are tested and will not cause damage to fabrics and materials installed in your aircraft.

### ENGINE

To clean the engine use any standard engine cleaning solvent. Spray the solvent over the engine using moderate pressure, and wash or rinse with clean water and allow to dry. Do not use pressure while rinsing with water. It is possible for water under high pressure to penetrate parts and filters and cause deterioration.

## GROUND HANDLING

Storage space required for the Aero Commander 200 is at a minimum. Required dimensions and clearances may be found by referring to a three view drawing (See 3-View Drawing Page). Special allowances must be made to clear optional installations such as additional radio antennas.

## TOWING

The aircraft may be easily moved about on a smooth and level surface by one man through the use of a tow-bar, furnished as standard equipment. The tow-bar is easily attached by insertion into the opening of the nose wheel axle.

### CAUTION

When it is necessary for more than one person to maneuver the aircraft during ground handling, do not exert pressure on any control surface, the propeller, or cowling. It is recommended that in such a case you utilize one person at each wing tip. Also, exert no force on tow-bar, to increase maximum turn radius. Excessive force may cause damage to the steering bell-crank, located on top of the nose gear strut. While steering with tow-bar or when using power tow, do not exceed 20° turn radius to the left or 15° turn radius to the right.

## TIE-DOWN

Whenever hangar facilities are not available, your aircraft should always be secured when not in use. A tie-down ring is located underneath the outboard leading edge of each wing and a combination tail skid and tie-down fitting underneath the aft end of the fuselage.

If excessive winds are expected, it is recommended that a tie-down be placed at the nose gear. The aircraft should be nosed into the wind, with the seat belt fastened to the control wheel to secure the aileron and elevator control surfaces.

## JACKING THE AIRCRAFT

You may jack the aircraft when necessary by using several methods. Two permanent jack point fittings are located forward and outboard of each main gear door. It is suggested that two hydraulic aircraft jacks and "support stand" for the aft section of the fuselage be used for this operation. One wheel may be jacked at a time by using an adapter (round bar or pipe inserted through the axle) and scissors-type jack.

During the "jacking down" operation, insure that the weight is firmly on all gear and proper compression of the struts occurs before attempting to remove the jacks. If the jacks are not removed swiftly and if the strut binds, momentarily, then releases while removing the jacks, damage to the wing may result.

### CAUTION

When jacking only one side of the aircraft using the permanent jack points, the support stand must be placed under the aft fuselage and a wheel chock installed.

### NOTE

While the aircraft is on jacks, exercise extreme caution by persons boarding the aircraft for any check, test, or operation, and then only after double checking to insure proper security of the aircraft. Compensate for weight forward of the CG by placing additional weight aft.

## BATTERY

The battery is located forward of the firewall and on the right side. The top cowl is easily removed for access to the battery compartment. Check the electrolyte level after each 25 hours of operation and add distilled water as necessary, being careful not to overflow the cells.

Excessive water consumption is usually an indication of internal damage or that the voltage regulator may require resetting.

The battery compartment is vented and a hose is provided for escape of fumes and excess electrolyte overboard. To insure proper operation, this vent and hose should be checked frequently for obstructions and deterioration.

## RECHARGING

The Aero Commander 200 has a negative ground system. During recharging operations, insure that positive leads are connected to positive terminals and negative leads to negative terminals. Check to see that all electronic equipment and master switches are in the OFF position.

## EXTERNAL POWER PLUG

Use the external power plug when using external power for equipment checks and starting. The external power plug is not recommended for recharging. Always check for proper connection. Always turn generator switch OFF.

## TIRES

The inflation pressure is 31 PSI in the main wheel tires and 24 PSI in the nose wheel tire. Maintaining proper tire inflation will minimize tread wear and aid in preventing tire rupture. While inflating tires, visually inspect them for cracks and breaks.



## SHOCK STRUTS

To Fill Main Gear: Deflate and compress, remove air valve, extend one inch and fill to overflowing with MIL-H-5606A hydraulic oil. Compress strut completely to remove excess oil. Replace air valve. Inflate to extend 3 $\frac{1}{8}$  inches with empty weight static load on strut, or 2 $\frac{1}{4}$  inches with maximum gross weight on strut.

Nose Gear: Use same procedure with the following exception: inflate to extend 1 $\frac{3}{4}$  inches with empty weight static load on strut.

### CAUTION

Always deflate strut before disassembly.

## BRAKES

The brake assemblies are self-adjusting and should require re-placement of brake lining as needed. The frequency of replacement is determined by use. It is recommended that brakes be used for slowing and stopping, and steering accomplished with the rudder pedals.

A hydraulic reservoir is located forward on the left side of the firewall. The fluid level should be checked frequently and filled with hydraulic oil MIL-H-5606A.

When brakes become weak, lining and fluid level should be checked. Added fluid as necessary, and after a bleeding operation, refill the reservoir.

### NOTE

The hydraulic fluid reservoir supplies fluid for brakes, landing gear and flaps.

## LANDING GEAR

The landing gear system consists of an engine driven hydraulic pump, which supplies hydraulic pressure for gear and flap operation at 1000-1300 PSI. The hydraulic reservoir should be checked frequently and filled to the level point with hydraulic oil MIL-H-5606A.

The landing gear pivot points and retraction links have oilite bearings throughout the system. For replacement, these bearings must be assembled with a press fit on both inner and outer bearing surfaces. When replacing bearings and adjusting linkage, always refer to the Aero Commander drawings pertaining to the aircraft serial number being serviced.

### NOTE

When ordering replacement parts always give the model and serial number of the aircraft for which the parts are intended.

There are six zerk grease fittings on the landing gear. These are located as follows: one each at the top-inside of the main gear struts and four on the nose gear strut. Two forward top and bottom, and two at top and bottom. These should be serviced every 25 hours of operation or every three months.

## PROPELLER BLADES

A regular pre-flight inspection should include a careful examination of the propeller blades for nicks and scratches. Any abnormal condition of the propeller or its operation should be referred to your Aero Commander dealer's Service Department.

### CAUTION

Always, while working in the vicinity of a propeller, insure that ignition is in the OFF position and stay clear of propeller.

## INDUCTION AIR FILTER

Efficient operation of the filter may become restricted by dust or foreign matter. Whenever this occurs, it is necessary that the filters be removed and cleaned with mineral spirits solvent. Use fresh solvent for final cleaning, and drain the filter thoroughly. If available, use a jet of dry, compressed air to blow off all liquid on the surface. If, after cleaning, the surfaces of the air filter show metallic wires through the remaining flocking material, the filter is no longer effective and should be replaced with a new part.

Dip the filter in clean engine lubricating oil, and allow it to drain overnight before installing.

## OIL SYSTEM

The oil capacity of the Aero Commander 200 engine is 12 quarts and should not be operated at less than 10 quarts. The oil installed at the factory is a mineral base oil, to facilitate ring seating and break-in of the engine. However, Continental Motors Corporation Specification MHS-24 is the only lubricant which meets all qualifications peculiar to this engine and is the only recommended lubricating oil.

Recommended oil viscosity is SAE-30, below 40°F; and SAE-50, above 40°F. Oil to meet the recommended specifications is detergent oil.

The oil should be changed after 50 hours of operation under normal conditions. It is recommended that oil be changed after flight; or prior to oil change, the engine should run until oil is up to normal operating temperature to insure complete oil drainage.

## BUNGEE FORCE RELEASE SYSTEM

The bungee force release mechanism relieves the amount of pilot effort necessary to keep the aircraft on a projected flight path while using flaps. Whenever it is necessary to remove the bungee system, it is recommended this be accomplished by removing the bolts rather than disturb the tension by changing the turnbuckle settings. However, resetting may be accomplished through the use of a spring scale and adjusting the turnbuckle.

The following are materials required, and procedures established for rigging the elevator, elevator trim tab, and bungee force release mechanism. These procedures are available with the special equipment required at your Aero Commander dealer's Service Department.

**SERVICE SCHEDULE**

ITEM	Pre-Flight	25 Hrs.	50 Hrs.	75 Hrs.	100 Hrs.	As Req.
Service Fuel Tanks						X
Check Engine Oil Level	X					
Check Battery Electrolyte Level		X				
Service Hydraulic Fluid Reservoir					X	
Clean Vacuum Regulator Valve Filter					X	
Drain Static Air Lines					X	
Drain Fuel Tank Drains	X					
Clean Gascolator Screen			X		X	
Change Engine Oil			X		X	
Drain Moisture From Engine Oil Sump					X	X
Clean Fuel Injection Control Valve Screen					X	
Clean Induction Air Filter		X	X		X	
Service Nose Gear Strut					X	X
Lubricate Wheel Bearings					X	
Lubricate Nose Wheel Steering Mechanism					X	
Check Magneto Breaker Points					X	X
Lubricate Control Wheel Linkage					X	
Lubricate Cabin Door Mechanism					X	
Lubricate Flap Servo Valve					X	
Lubricate Landing Gear Retract Mechanism					X	
Lubricate Elevator Tab Mechanism					X	
Lubricate Flap Actuators					X	
Lubricate Aileron Bell Cranks					X	
Service Main Gear Struts					X	X
Lubricate Landing Gear Door Hinges					X	
Lubricate Rudder Pedals					X	
Lubricate Cowl Flap Hinges					X	X
Clean and Check Spark Plugs					X	X
Check Magneto Timing					X	X
Replace Gyro Instrument Filters					X	
Check Brake Lining Wear					X	X
Service Landing Gear Actuator					X	
Lubricate Landing Gear Uplock Rollers					X	
Lubricate Flap Track Rollers					X	
Service Seat Track Rollers					X	